

SuitCase[®] X-TREME[™] 8VS & 12VS

Issued Jan. 2010 • Index No. M/6.41

Voltage-Sensing
Wire Feeder



Quick Specs

Industrial Applications

Shipbuilding
Construction
Heavy Manufacturing
Rental

Processes

MIG (GMAW)
Flux Cored (FCAW)

Input Power 14–48 VDC Operating Voltage
110 VDC Maximum OCV

Wire Feed Speed 50–780 IPM (1.3–19.8 m/min)

Weight 8VS: 28 lb (13 kg)
12VS: 35 lb (15.9 kg)

The Power of Blue.[®]

Smaller 8VS size for shipbuilding, maintenance or wherever a lighter, smaller, more portable feeder is required. Same great features of its big brother the X-TREME 12VS. Ergonomically sound, lightweight unit is well balanced for ease of carrying to remote welding sites. Fits through a 14 in (25 mm) manhole/manway.

Polypropylene case with built-in slide rails and the ability to open the door to change wire with feeder in vertical position.

Potted and trayed main printed circuit board for the harshest environments adds exceptional reliability. Board has full-trigger isolation so a shorted gun trigger will not affect feeder operation.

Improved contactor for high-amperage, high duty cycle applications (8VS: 330 A at 60%, 12VS: 425 A at 60%).



Trigger hold, wire jog, and gas purge are all located on front panel (8VS: Trigger Hold optional).

Digital meters with SunVision[™] technology can display voltage and wire speed, and also amperage if desired. Meters can be seen clearly even in direct sunlight (8VS: Meters optional).

Wider voltage range for small and large wires with no contactor chatter or arc outages.

Double-filtered gas valve helps keep dirt from clogging and affecting gas flow.

Excellent starts and improved superior arc performance for all types and sizes of wires whether using CV or CC power supply.

Specifications (Subject to change without notice.)



(Use with CC/CV, DC Power Sources.)

Model	Input Power	Welding Power Source Type	Input Welding Circuit Rating	Wire Speed	Electrode Wire Diameter Capacity	Max. Spool Size Capacity	Dimensions	Net Weight
8VS	Operates on open-circuit voltage and arc voltage: 14–48 VDC/110 Max OCV	CC or CV DC power sources. AC type not recommended.	330 A at 60% Duty Cycle	50–780 IPM (1.3–19.8 m/min)	Solid Wire: .023–.062 in (0.6–1.6 mm) Flux Cored: .030–.062 in (0.8–1.6 mm)	8 in (203 mm) 14 lb (6.4 kg)	H: 12-3/4 in (324 mm) W: 7-1/4 in (184 mm) D: 18 in (457 mm)	28 lb (13 kg)
12VS			425 A at 60% Duty Cycle	dependent on arc voltage	Solid Wire: .023–5/64 in (0.6–2.0 mm) Flux Cored: .030–5/64 in (0.8–2.0 mm)	12 in (305 mm) Up to 45 lb (20 kg)	H: 15-1/2 in (394 mm) W: 9 in (229 mm) D: 21 in (533 mm)	35 lb (15.9 kg)



Wire feeder is warranted for 3 years, parts and labor.

MADE IN USA
APPLETON, WI



Miller Electric Mfg. Co.
An Illinois Tool Works Company
1635 West Spencer Street
Appleton, WI 54914 USA

Equipment Sales US and Canada
Phone: 866-931-9730
FAX: 800-637-2315
International Phone: 920-735-4554
International FAX: 920-735-4125

Web Site
www.MillerWelds.com



Control Panels

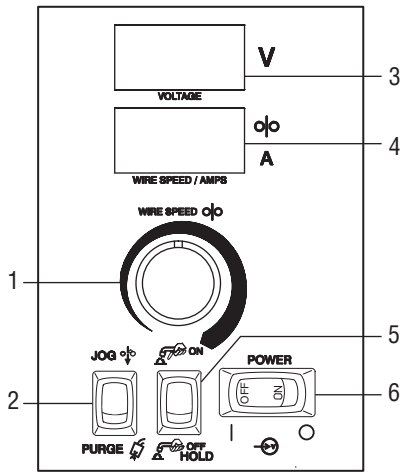

SuitCase X-TREME 8VS

1. Wire Speed Control
2. Jog/Purge Switch
3. Voltmeter (Optional)
4. Wire Speed/Amperage Meter (Optional)
5. Trigger Hold Switch (Optional)
6. Power Control Switch

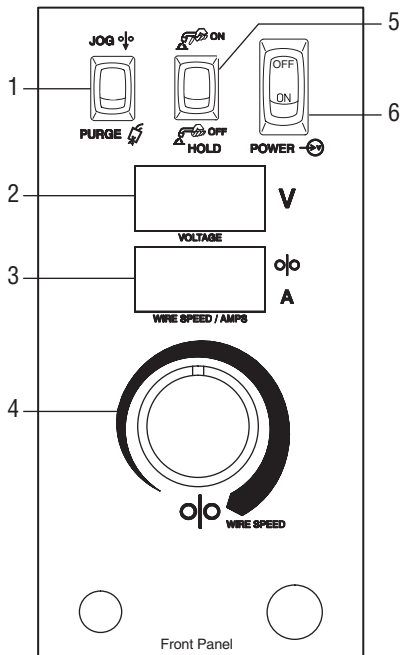

SuitCase X-TREME 12VS

1. Jog/Purge Switch
2. Voltmeter
3. Wire Speed/Amperage Meter
4. Wire Speed Control
5. Trigger Hold Switch
6. Power Control Switch

Drive Roll Kits (Order from Miller Service Parts.)

Select drive roll kits from chart below according to type and wire size being used. Drive roll kits include 2 drive rolls, the necessary guides and feature an anti-wear inlet guide.

Wire size	"V" groove for hard wire	"U" groove for soft wire or soft-shelled cored wires	"V" knurled for hard-shelled cored wires	"U" cogged for extremely soft wire or soft-shelled cored wires (i.e., hard facing types)
.023 / .025 in (0.6 mm)	#087 131	—	—	—
.030 in (0.8 mm)	#079 594	—	—	—
.035 in (0.9 mm)	#079 595	#044 749	#079 606	—
.040 in (1.0 mm)	#161 189	—	—	—
.045 in (1.1/1.2 mm)	#079 596	#079 599	#079 607	#083 318
.052 in (1.3/1.4 mm)	#079 597	#079 600	#079 608	#083 317
1/16 in (1.6 mm)	#079 598	#079 601	#079 609	#079 614
.068/.072 in (1.8 mm)	—	—	#089 984	—
5/64 in (2.0 mm)	—	#079 602	#079 610	#079 615

Ordering Information

Power Source and Options	Stock No.	Description	Qty.	Price
SuitCase® X-TREME™ 8VS	#951 181	With Bernard® Q300 Gun (Without meters or trigger hold)		
	#951 182	With Bernard® Q300 Gun & meters		
	#951 183	With Bernard® Q300 Gun, meters & trigger hold		
Meter Kit	#300 331	Field. For X-TREME 8VS		
Trigger Hold	#300 332	Field. For X-TREME 8VS		
SuitCase® X-TREME™ 12VS	#951 184	With Bernard® Q300 Gun		
	#951 185	With Bernard® Dura-Flux™ gun		
Flowmeter Kit	#300 343			
Inline Filter	#195 189			
Spool Adapter	#047 141	For 14 lb spools/X-TREME 12VS only		
Guns				
Bernard® Q300 (GMAW)		See Welding Components and Parts Guide		
Bernard® Dura-Flux™ (FCAW)		See Welding Components and Parts Guide		
Ironmate™ 1260 (FCAW)		See Lit. Index No. AY/16.0		
Roughneck® C-Series (GMAW)		See Lit. Index No. AY/17.0		
Power Sources				
XMT® Series		See Lit. Index No. DC/18.8 and DC/18.83		
Dimension™ Series		See Lit. Index No. DC/19.2		
Gold Star® Series		See Lit. Index No. DC/8.1		
Mark VI™ and Mark VIII®-2		See Lit. Index No. DC/9.8 and DC/10.0		
Big Blue® Turbo		See Lit. Index No. ED/10.3		
Big Blue® 300 Pro		See Lit. Index No. ED/5.21		
Big Blue® 400 and 500		See Lit. Index No. ED/10.8		
Big Blue® Air Pak™		See Lit. Index No. ED/10.5		
Bobcat™		See Lit. Index No. ED/4.4		
Trailblazer®		See Lit. Index No. ED/4.77 and ED/4.78		
Consumables				
Drive Rolls				
Wire				

Date:

Total Quoted Price:

Distributed by:

